

Are your **MRI contrast agents** cost-effective?

Learn more about generic **Gadolinium-Based Contrast Agents**.



FRESENIUS  
KABI

caring for life

**AJNR**

**MR-directed brain biopsy: feasibility study.**

A C Mamourian, R E Rhodes, J J Duda, J Towfighi, W S White, R B Page, D E Cunningham and R A Lehman

*AJNR Am J Neuroradiol* 1988, 9 (3) 510-512  
<http://www.ajnr.org/content/9/3/510.citation>

This information is current as  
of April 17, 2024.

## MR-Directed Brain Biopsy: Feasibility Study

Alexander C. Mamourian,<sup>1</sup> Randall E. Rhodes, John J. Duda, Javad Towfighi, William S. White, Robert B. Page, David E. Cunningham, Ralph A. Lehman

MR imaging can provide cross-sectional images in multiple imaging planes with equal resolution and improve localization of abnormal tissue over that afforded by CT [1, 2]. MR-directed biopsy of the body has already been safely performed [3]; however, MR-directed biopsy of the brain is potentially more difficult and risky because of the problems involved in identifying possible intracranial hemorrhage [4] that may accompany the biopsy.

Blood within vessels enhances after the administration of gadolinium-DTPA (Gd-DTPA), an IV MR contrast agent [5, 6]. We wondered whether fresh intracranial hemorrhage would enhance as well. In this paper we present our results in seven dogs after brain biopsy and injection of contrast material. Needle artifact was evaluated by using a brain phantom, which was also used to develop a surface localization technique suitable for MR imaging.

### Materials and Methods

We anticipated that problems might arise with conventional brain biopsy instruments because of the strong magnetic field used for MR imaging. The Feild-Lee brain biopsy needle (Fig. 1) was selected because it is commonly used for CT biopsy at our institution and its design seemed to lend itself well to MR biopsy. The outer cylinder is 302-grade stainless steel while the inner cylinder and stylet are 304-grade stainless. These needle components were tested for their ferromagnetic properties by suspending them from a thread in the bore of a research 1.9-T Oxford spectroscopy magnet [7]. Deflection from vertical was measured and force calculated.\* Imaging artifact was evaluated on a 0.15-T resistive magnet using a 7 × 16 × 11 cm brain phantom made from a hydrocarbon gel.† A 4-cm piece of styrofoam was imbedded in the gel to provide a target for biopsy.

Propylene glycol-filled tygon tubing was used to provide a surface marker for biopsy. These appear as high signal on T1- and T2-weighted MR images. The phantom was scanned in two orthogonal planes and a marker tube was taped to the phantom at the approximate level determined from the slice position where the lesion was best seen. Scans were then repeated to verify placement, and corrections were made. These two tubes would then describe the entry point for the needle, and depth could be measured directly from

the MR images.

To assess our ability to image intracranial hemorrhage, seven dogs were anesthetized with pentobarbital and we performed brain biopsies via parietal burr holes. Bilateral biopsies were performed to minimize the number of animals needed for a reasonable number of samples. The first two animals were studied on the 0.15-T resistive unit. A prebiopsy coronal MR image, 500/30 (TR/TE), was obtained. This T1-weighted technique was selected to optimize contrast [8]. After biopsy, but before contrast injection, the scan was repeated. Gd-DTPA<sup>‡</sup> at 0.1 mmol/kg was then injected and the scan repeated. A second biopsy was performed in the opposite hemisphere; contrast was again injected, followed by another scan. The next five dogs were studied on a Siemens 0.5-T superconducting system and the same technique was used except that contrast was injected only once at a dosage of 0.2 mmol/kg in four animals and 0.1 mmol/kg in the fifth. Postbiopsy contrast-enhanced scans were evaluated for any regions of abnormally high signal and were then compared with the precontrast study. All animals received a lethal pentobarbital injection at the conclusion of imaging and an autopsy was performed. Brains were excised and fixed in formalin. The findings at brain sectioning were correlated with the MR findings.

### Results

We did not find that postbiopsy hemorrhage was apparent on the unenhanced scans. In the first two animals, five of eight hemorrhages found at autopsy were missed on the contrast-enhanced MR scans. In the next four animals, in which we used a higher dosage of contrast (0.2 mmol/kg) and the 0.5-T system, only four of 25 hemorrhages were missed (Fig. 2). Two of these were within the ventricular system, and one was an extremely fine hemorrhage within the needle tract. The largest and probably most significant hemorrhage missed was a moderate (3 × 10 × 20 mm) subdural in the fourth animal. In the last animal, in which contrast was again administered at the lower dosage, four or five hemorrhages were missed.

We found that the stylet of the Feild-Lee biopsy was strongly deflected in the magnet. The deflection measured 86° and the calculated force was 38,257 dynes<sup>§</sup>. The two

$$* \text{ Force} = \frac{(\text{mass of metal component})(\text{gravitational constant})(\sin \theta)}{\cos \theta \ (\theta = \text{deflection from vertical})}$$

† Oil Center Research, Lafayette, LA.

‡ Magnevist, Berlex Laboratories, Inc., Cedar Knolls, NJ.

$$§ \text{ } F = \frac{2.73\text{g} (980 \text{ g/m/sec}^2) 0.99756}{0.06976} = 38,257 \text{ dynes}$$

Received June 29, 1987; accepted after revision November 12, 1987.

<sup>1</sup> All authors: Department of Radiology, The Milton S. Hershey Medical Center, The Pennsylvania State University, P.O. Box 850, Hershey, PA 17033. Address reprint requests to A. C. Mamourian.

metal cylinders had no deflection in the magnet. The stylet produced a large artifact in the brain phantom, presumably because of its ferromagnetic properties. The metal cylinders also produced a significant artifact. In our evaluation of needle localization we found that air within the bore of the outer plastic sleeve of the Feild-Lee needle provided adequate contrast with the brain phantom to allow localization of the needle tip. This sleeve is designed to be left in position after removal of the metal components to eliminate artifacts on CT images. Using the marker tubes and the plastic sleeve, we found that the needle could be consistently positioned adjacent to the phantom lesion. In practice, we found it was

difficult to image the plastic sleeve because blood and CSF often filled the bore, displacing the air as a source of contrast.

**Discussion**

Initially, we were discouraged with our biopsy results on the 0.15 T imager. We felt that the enhancement of the hemorrhages was probably not due to the usual mechanism of breakdown of blood-brain barrier [9] but rather to the direct accumulation of gadolinium-enhanced blood. We questioned whether the dosage we used was insufficient to allow adequate enhancement. While we recognized that at high concentrations of Gd-DTPA image contrast may be reduced as the T2 shortening effects of Gd-DTPA predominate [8], a dosage of 0.2 mmol/kg is not sufficient to observe this phenomenon, as evidenced by our improved results at this dosage. We thought that the improved visualization of hemorrhage could be due to improved resolution on the higher field unit, but our poor results at 0.5 T in the last animal using the 0.1 mmol/kg dosage suggest that dosage plays a more important role. We did not consider the effects of intracellular deoxyhemoglobin on image contrast since these effects are reported to be negligible at the field strengths used [10, 11].

With a dosage of 0.2 mmol/kg, we saw 21 of 25 hemorrhages. The small hemorrhage along the needle tract was probably not resolvable on the 5-mm sections used but unlikely to be of clinical significance. Unless extremely fine slices are used, which is not practical, small hemorrhages will be missed because of volume averaging. The nonvisualization of blood within the aqueduct and the fourth ventricle in two cases may be explained by CSF flow effects in these regions. This flow causes dephasing of involved protons and is usually manifested as diminished signal in the aqueduct, third, or

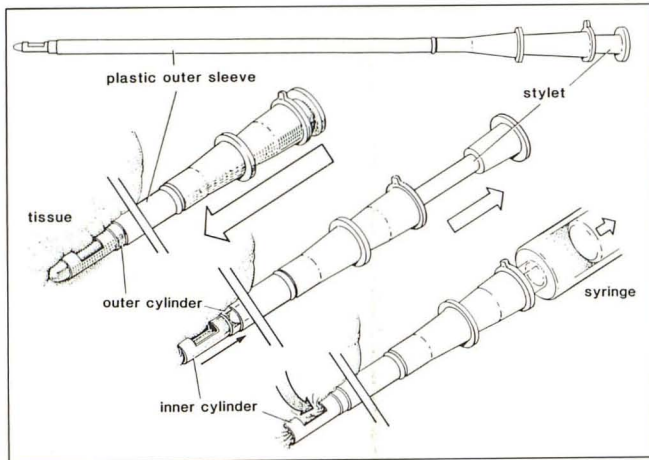

**Fig. 1.**—Illustration shows the four components of Feild-Lee needle. During biopsy, suction is applied and outer cylinder is passed over inner cylinder cutting off a fragment of tissue in side aperture of inner cylinder.

**Fig. 2.**—A-C, MR image 500/30 of dog after biopsy and contrast injection (A) demonstrates small (3-4 mm) brainstem hemorrhage (straight arrow) and larger temporal lobe hemorrhage (curved arrow). Increased signal can also be seen in region of left lateral ventricle and along needle path. Precontrast MR image after biopsy (B) demonstrates asymmetry of lateral ventricles but no definite hemorrhage. Brainstem and temporal lobe hemorrhages were confirmed at autopsy (C).

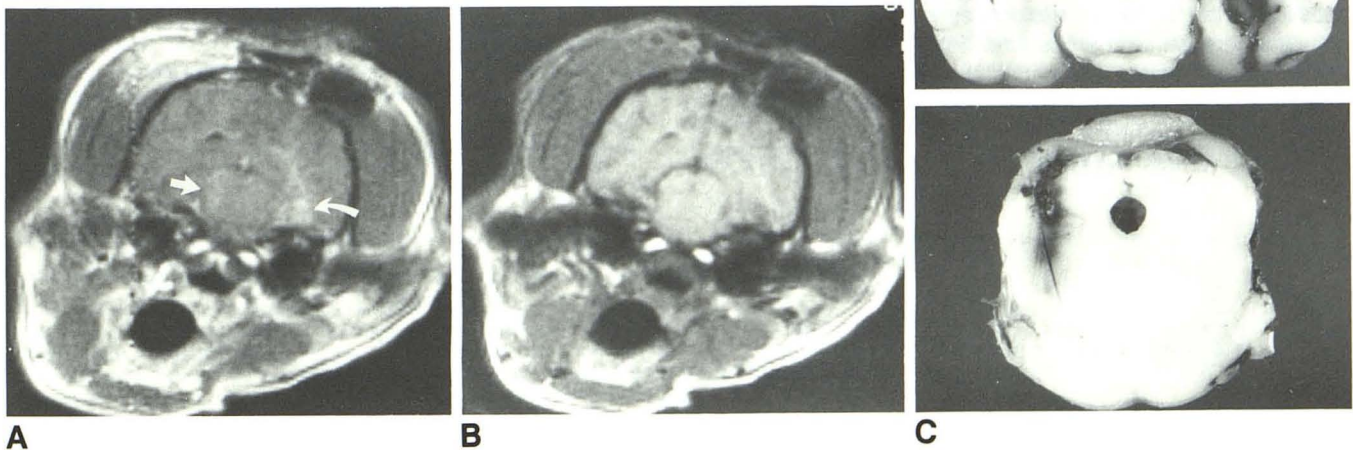

fourth ventricle [12]. This dephasing probably offset the contrast-induced enhancement in these cases. The subdural hemorrhage, which was the largest, occurred in an animal in which profuse bleeding was encountered while drilling the burr holes. Burr holes in all animals were made prior to biopsy in a separate facility. The prebiopsy scout scan in this animal showed the hemorrhage but it was not evident after biopsy and injection of contrast. Since bleeding should have stopped well before the administration of contrast, we would not expect the gadolinium-enhanced blood to freely accumulate in this space. The diminished lesion contrast after the injection of Gd-DTPA may reflect differences in distribution of gadolinium within perfused brain and the subdural. In any event, it seems certain that this hemorrhage occurred prior to biopsy and suggests that the contrast must be injected close to the time of the bleeding for enhancement of fresh hemorrhage to occur. Thus, while four hemorrhages were not visible on postenhanced scans, no significant intraparenchymal hemorrhage caused by the biopsies was missed.

Two problems were encountered with the Feild-Lee biopsy needle. The stylet was strongly deflected in the magnet, and would be hazardous in a strong magnetic field. As an alternative, the stylet could simply be manufactured from titanium. The second problem was encountered while trying to image the plastic sleeve during experiments when fluid filled the bore. A Teflon obturator placed within the sleeve during the scan would displace the fluid and appear as a linear low-signal zone. This would permit precise needle localization.

The actual biopsy is in many respects simpler with MR than with CT. Because of the multiplanar capabilities of MR, the lesion and needle path can be imaged in a single slice. Even an oblique approach is feasible in scanners with oblique imaging capabilities. In addition, sagittal and coronal MR images can be directly superimposed on angiograms, which may be useful in determining the safest approach to a lesion [13]. Surface localization does not seem to be a significant obstacle according to our phantom results. For these reasons, MR-directed biopsy should allow some lesions to be approached that otherwise would be inaccessible without specialized stereotaxic equipment.

Because of the strong magnetic field used in MR imaging, nonferrous tools must be used for the burr holes. This equipment could be manufactured to meet specific requirements or adapted from more readily available beryllium copper tools used in the chemical and oil industries. Depending on the location of the lesion and the desired approach, the headcoil may interfere with the procedure. Saddle-shaped coils allow easier access to the head than the more commonly used Helmholtz coils, and this limitation must be taken into account when planning the biopsy.

No brain tumors were actually biopsied in this study. We

expect that in most cases the Gd-DTPA will enhance the tumor as well as areas of biopsy-induced hemorrhage. This may prove to be a problem in practice and may require a prebiopsy gadolinium scan for comparison. However, not all intraaxial lesions will enhance, and the often large areas of peritumoral edema usually do not enhance either [14]. While other practical considerations remain to be resolved, these results suggest that MR-directed biopsy is feasible with equipment and techniques that are currently available.

#### ACKNOWLEDGMENTS

We thank James Griffith, John Koveleski, Carol Mancuso, Sharon Hurst, and Michelle Mease for their generous assistance and Lisa Bauman for preparing the manuscript. We also thank Berlex Laboratories, Inc., for providing the contrast material.

#### REFERENCES

- Bradley WG, Waluch V, Yadley RA, Wycoff RR. Comparison of CT and MR in 400 patients with suspected disease of the brain and cervical spinal cord. *Radiology* **1984**;152:695-702
- Herman SD, Friedman AC, Radecki PD, Caroline DF. Incidental prostatic carcinoma detected by MRI and diagnosed by MRI/CT-guided biopsy. *AJR* **1986**;146:351-352
- Mueller PR, Stark DD, Simeone JF, et al. MR-guided aspiration biopsy: needle design and clinical trials. *Radiology* **1986**;161:605-609.
- Moran CJ, Naidich TP, Marchoski JA. CT-guided needle placement in the central nervous system: results in 146 consecutive patients. *AJNR* **1984**;5:419-426, *AJR* **1984**;143:861-868
- Carr DH, Brown J, Bydder GM, et al. Gadolinium-DTPA as a contrast agent in MRI: initial clinical experience in 20 patients. *AJR* **1984**;143:215-224
- Kilgore DP, Breger RK, Daniels DL, Pojonas KW, Williams AL, Haughton VM. Cranial tissues: normal MR appearance after intravenous injection of GD-DTPA. *Radiology* **1986**;160:757-761
- New PF, Rosen BR, Brady TJ, et al. Potential hazards and artifacts of ferromagnetic and nonferromagnetic surgical and dental materials and devices in nuclear magnetic resonance imaging. *Radiology* **1983**;147:139-148
- Runge VM, Clanton JA, Herzer WA, et al. Intravascular contrast agents suitable for magnetic resonance imaging. *Radiology* **1984**;153:171-176
- Felix R, Fiegler W, Schorner W, Laniado M, Calussen C, Niendorf HP. MR imaging of brain tumors using Gd-DTPA. Presented at the annual meeting of the Radiological Society of North America, Chicago, **1985**
- Bryan RN. MRI of hemorrhage. Presented at the Clinical MRI Symposium, San Diego, May **1987**
- Gomori JM, Grossman RI, Goldberg HI, Zimmerman RA, Bilaniuk LT. Intracranial hematomas: imaging by high-field MR. *Radiology* **1985**;157:89-93
- DeLaPaz RL, Enzmann DR, Robin JB, Wright A. Diagnostic significance of intracranial cerebrospinal fluid motion in clinical MR imaging studies. Presented at the annual meeting of the Radiological Society of North America, Chicago, **1986**
- Gahbauer H, Sturm V, Schlegel W, et al. Combined use of stereotaxic CT and angiography for brain biopsies and stereotaxic irradiation. *AJNR* **1983**;4:715-718
- Brant-Zawadzki M, Berry I, Osaki L, Brasch R, Murovic J, Norman D. Gd-DTPA in clinical MR of the brain: I. intraaxial lesions. *AJNR* **1986**;7:781-788