

Are your MRI contrast agents cost-effective?

Learn more about generic Gadolinium-Based Contrast Agents.



**FRESENIUS
KABI**

caring for life

AJNR

Technical note: mobile CT scanner gantry for use in the operating room.

H Okudera, S Kobayashi and K Sugita

AJNR Am J Neuroradiol 1991, 12 (1) 131-132

<http://www.ajnr.org/content/12/1/131.citation>

This information is current as of June 3, 2024.

Technical Note: Mobile CT Scanner Gantry for Use in the Operating Room

Hiroshi Okudera,¹ Shigeaki Kobayashi,¹ and Kenichiro Sugita²

In modern neurosurgical practice, CT is a well established, important examination for planning surgery and perioperative care. Recently, CT scanners have been used for intraoperative imaging during craniotomy [1-6].

In this paper, we report a newly developed mobile CT scanner gantry with a modified fork-lift gantry carrier. This system enables the radiologist to obtain CT images during surgery or immediately after surgery in the operating room; for example, in patients who cannot be transferred to the ordinary scanner room in the radiology department.

Materials and Methods

To develop a mobile CT gantry, we designed two gantry systems, one a rail-track system and the other a gantry carrier system. The rail-track system requires certain modifications to the floor of the operating room, and so is expensive and time-consuming to install. Furthermore, the track on the floor of the operating room is a physical obstacle for staff. We finally settled on the second type, the gantry carrier system (Fig. 1). Theoretically, this system can be used with any CT scanner gantry in any operating room. A small forklift is

designed to move the gantry unit of the scanner, which we call the gantry carrier (Nihon-Yusou, Nagaokakyo, Japan). This lift can take a weight of 2000 kg and move at a speed of 20 cm/sec in any direction. The gantry of the TCT-300 scanner (Toshiba, Tokyo, Japan) is fixed to the gantry carrier (Fig. 2). The X-ray generator of the scanner is placed inside the operating room and the computer and the console unit outside. Because an exclusively designed 10-meter-long cable from the console unit and the high-voltage generator is used, the gantry can move within an area 10 meters in diameter. A phantom test using a digitalized operating table (Mizuho, Tokyo, Japan) [7] in place of a scanner bed, performed in the operating room to evaluate the influence of movement of the gantry and cable, showed that there was no deterioration in image quality.

Results

Movement of the scanner gantry by gantry carrier was smooth and silent. No mechanical troubles were encountered. The images from the mobile scanner in the operating room were of the same quality as those produced in the factory.

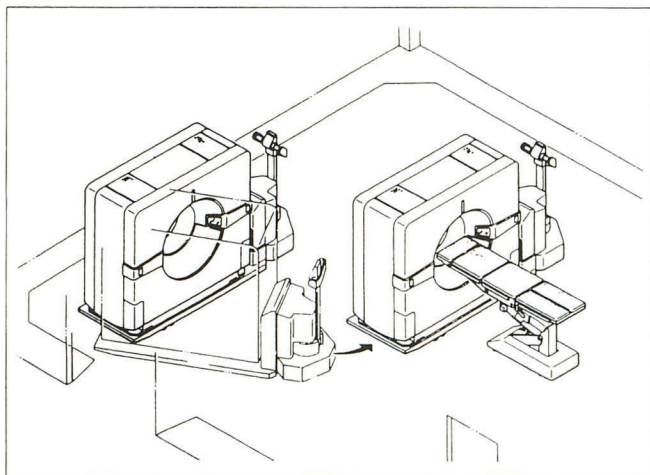

Fig. 1.—Line drawing shows total system placed in the operating room.

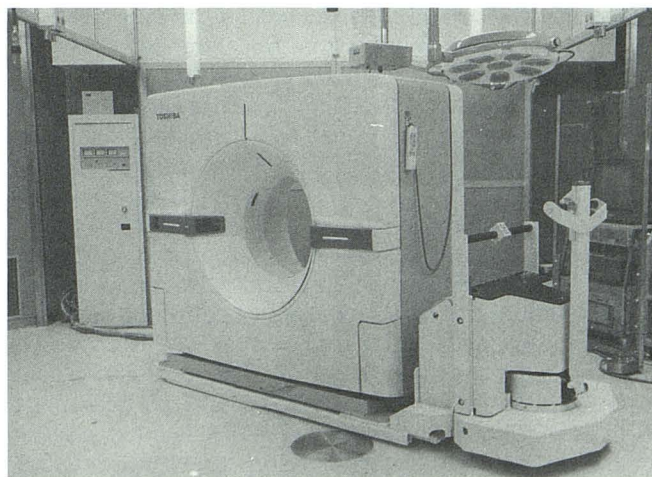

Fig. 2.—Photograph of mobile CT gantry on gantry carrier. The scanner can be moved in any direction by operating the carrier.

Received September 7, 1989; revision requested November 16, 1989; revision received December 18, 1989; accepted December 27, 1989.

¹ Department of Neurosurgery, Shinshu University School of Medicine, Asahi 3-1-1, Matsumoto, 390 Japan. Address reprint requests to H. Okudera.

² Department of Neurosurgery, Nagoya University School of Medicine, Nagoya, Japan.

The total mobile gantry system, including the scanner gantry and the gantry carrier, weighed 1200 kg.

Discussion

Since the epoch-making introduction of CT scanning, it is no exaggeration to say that diagnosis and surgery in modern neurosurgical practice have come to rely very heavily on the findings provided by CT. This method may be especially useful for patients during and immediately after surgery. However, because patients undergoing surgery need anesthetic care involving various kinds of monitors, respirators, and other equipment, transfer to the ordinary scanning room has been limited and often impossible. To overcome this problem, many hospitals have installed a CT scanner in or near the operating room [2-4]. We have installed such a scanner in the operating room of our hospital and have obtained CT images intraoperatively and/or immediately after surgery using a digitally controlled operating table instead of a scanner bed [4-6]. However, we found that the fixed-type scanner gantry needed some extra time to set the patient for scanning and limited the desired arrangement of instruments in the operating room [6].

The mobile gantry system described in this paper has been developed to increase the efficiency of CT scanning in the operating room. Since May 1988, we have used the mobile gantry system to scan patients immediately after operation for all major surgical cases in our hospital. The immediate scanning in the operating room enables us to check for such

postoperative complications as hemorrhage, hydrocephalus, and brain edema, with the result that reoperation can be performed readily if necessary.

The major advantage of the mobile gantry system is that it saves time when scanning intraoperatively or immediately after surgery in the operating room. Furthermore, the gantry can be put aside when it is not in use. The only disadvantage may be that the total system is heavy, requiring careful attention when operating the gantry carrier. The operability is, however, basically the same as that for a conventional mobile-type X-ray unit.

REFERENCES

1. Shalit MN, Israeli Y, Matz S, Cohen ML. Intraoperative computerized axial tomography. *Surg Neurol* **1979**;11:382-384
2. Lunsford LD, Parrish R, Albright L. Intraoperative imaging with a therapeutic computed tomographic scanner. *Neurosurgery* **1984**;15:559-561
3. Engle DJ, Lunsford LD. Brain tumor resection guided by intraoperative computed tomography. *J Neurol Oncol* **1987**;4:361-370
4. Okudera H, Sugita K, Kobayashi S, et al. Clinical experiences and utility of a computerized tomographic scanner in the operating room. The operating CT system. *Neuroradiology* **1988**;30:461
5. Okudera H, Sugita K, Kobayashi S, Kimishima S, Yoshida H. Neurosurgical operating computerized tomographic scanner system—CT scanner in the operating theater. [Author's trans.] *Prog CT* **1988**;10:665-671
6. Okudera H, Kobayashi S, Sugita K. Intraoperative CT scan findings. Report of two cases with resection of glial tumors. *Neuroradiology* (in press)
7. Okudera H, Kobayashi S, Kanemaru K, Kiyono S, Sugita K. Development of digitalized operating table for microsurgery. [Author's trans.] *Jpn J Med Inst* **1988**;58:466-468

The reader's attention is directed to the commentary on this article, which appears on the following pages.